

**SI 0028**

For technical personnel only!

1/1

# SERVICE INFORMATION

## BROKEN VALVE AT END OF STEM

### VALVE TIMING ERRORS ARE THE PRINCIPAL CAUSE

#### SITUATION

Frequently, after a repair to a cylinder head, valve breakage occurs in the area of the valve cotters (Fig. 1) after a short running time. Valves with a stem diameter of 7 mm or less are especially prone to this problem.



Fig. 1: forced breakage at groove

#### CAUSE OF THE PROBLEM

Most often, this fault is caused by a toothed belt that has jumped a tooth or is incorrectly adjusted. This causes the piston to collide with the valve, which has not yet completely closed (Fig. 2), during operation. When this happens, the piston and camshaft exert major forces on the valve stem. Due to its design and installation situation, the valve experiences the highest bending moment in the area of the lower groove. As the valve can only bend slightly in its guide, it bends and breaks at this groove (Fig. 3).

Other reasons for failure:

- Pre-damaged, bent tappets
- Worn valve guides
- Bent valves
- Bent rocker arm or cam follower
- Incorrectly fitted valve cotters/springs
- The waiting time for the installation of new hydraulic valve tappets was not complied with.

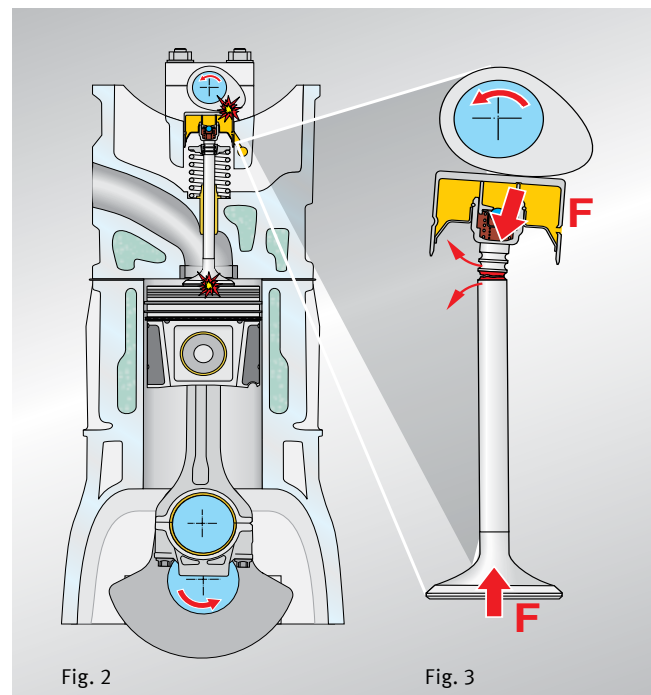

Fig. 2

Fig. 3

#### NOTE

Valve breakages at the end of the stem are always the result of inexpert installation or unfavourable operating conditions. This damage is not caused by material faults.

All content including pictures and diagrams is subject to change. For assignment and replacement, refer to the current catalogues or systems based on TecAlliance.